

MODERN GAS CREMATORIUM MODEL III—SEMI PERMANENT PITCHED SHEET ROOF TYPE

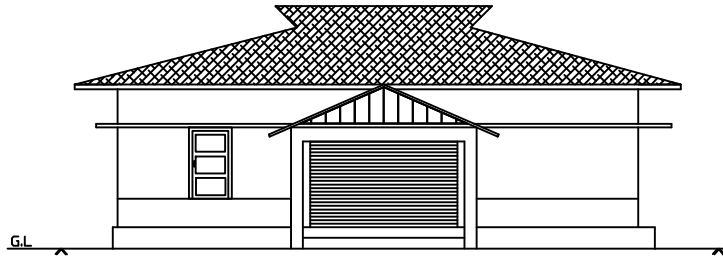

ELEVATION

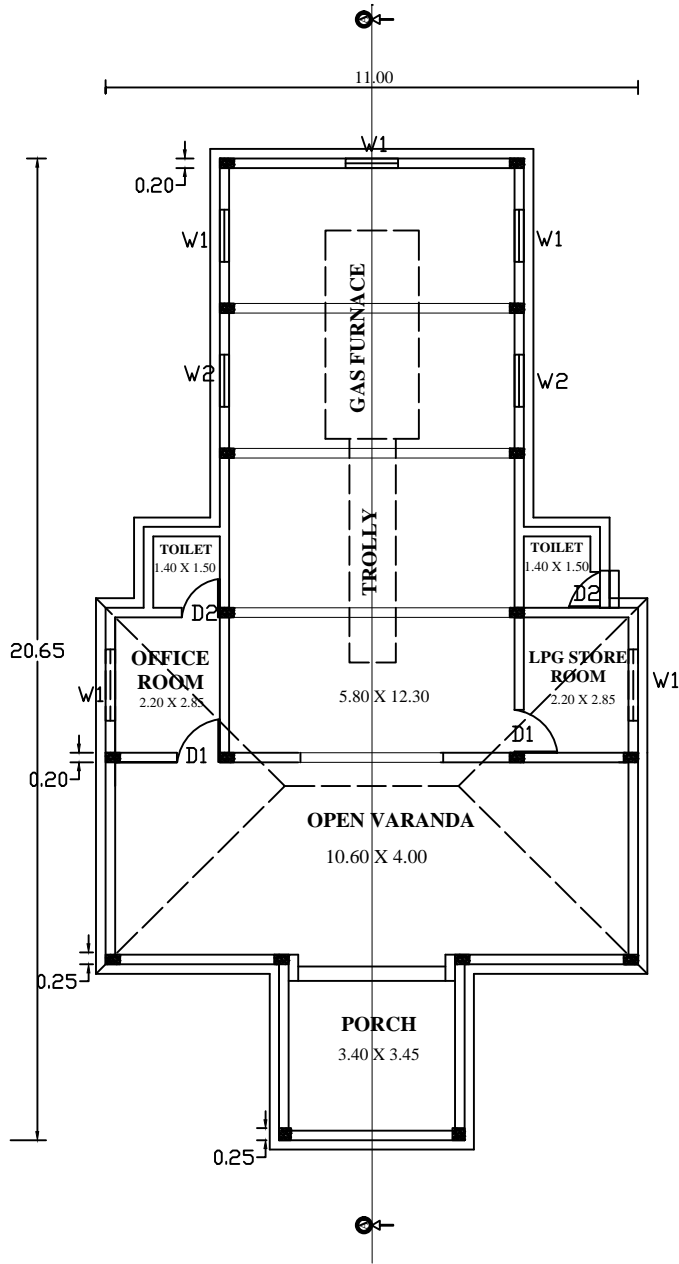

PLAN FOR CREMATORIUM

SPECIFICATION	
DOOR	D1 - 0.90 X 2.10 (2 No:S)
	D2 - 0.80 X 2.10 (2 No:S)
WINDOW	W1 - 1.50 X 1.50 (5 No:S)
	W2 - 1.10 X 1.50 (2 No:S)
ALL DIMENSIONS ARE IN M	

Total Plinth area = 145.98 m²

Porch area = 11.73 m²

WATCHMAN SHED

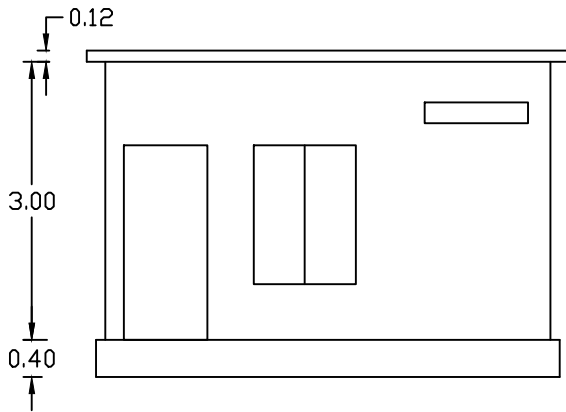

ELEVATION

SPECIFICATIONS

D1 - 0.90 X 2.10 (1 NO)
D2 - 0.80 X 2.10 (1 NO)
W - 1.10 X 1.50 (3 NO.S)
FOUNDATION-R.R-0.60 X 0.60 Sized
BASEMENT - R.R. - 0.40 X 0.40 Sized
ROOF SLAB - R.C.C. - 1:1.5:3
SCALE - 1:1
ALL DIMENSIONS ARE IN METER

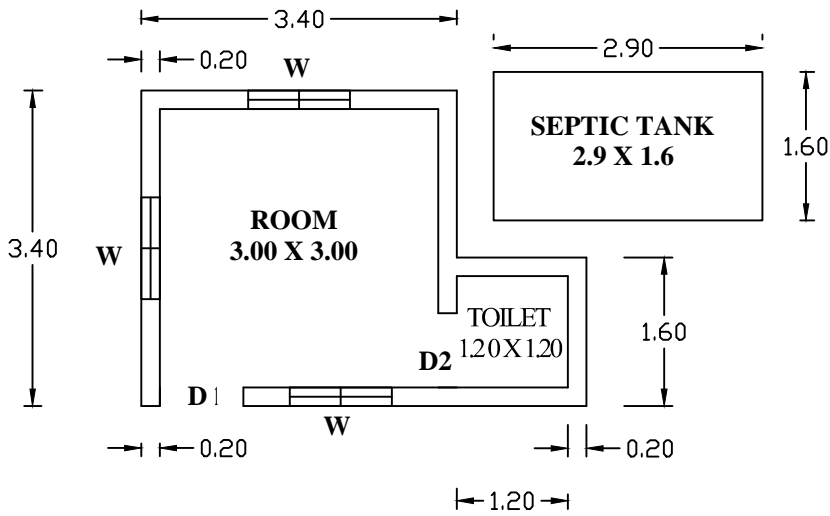

PLAN

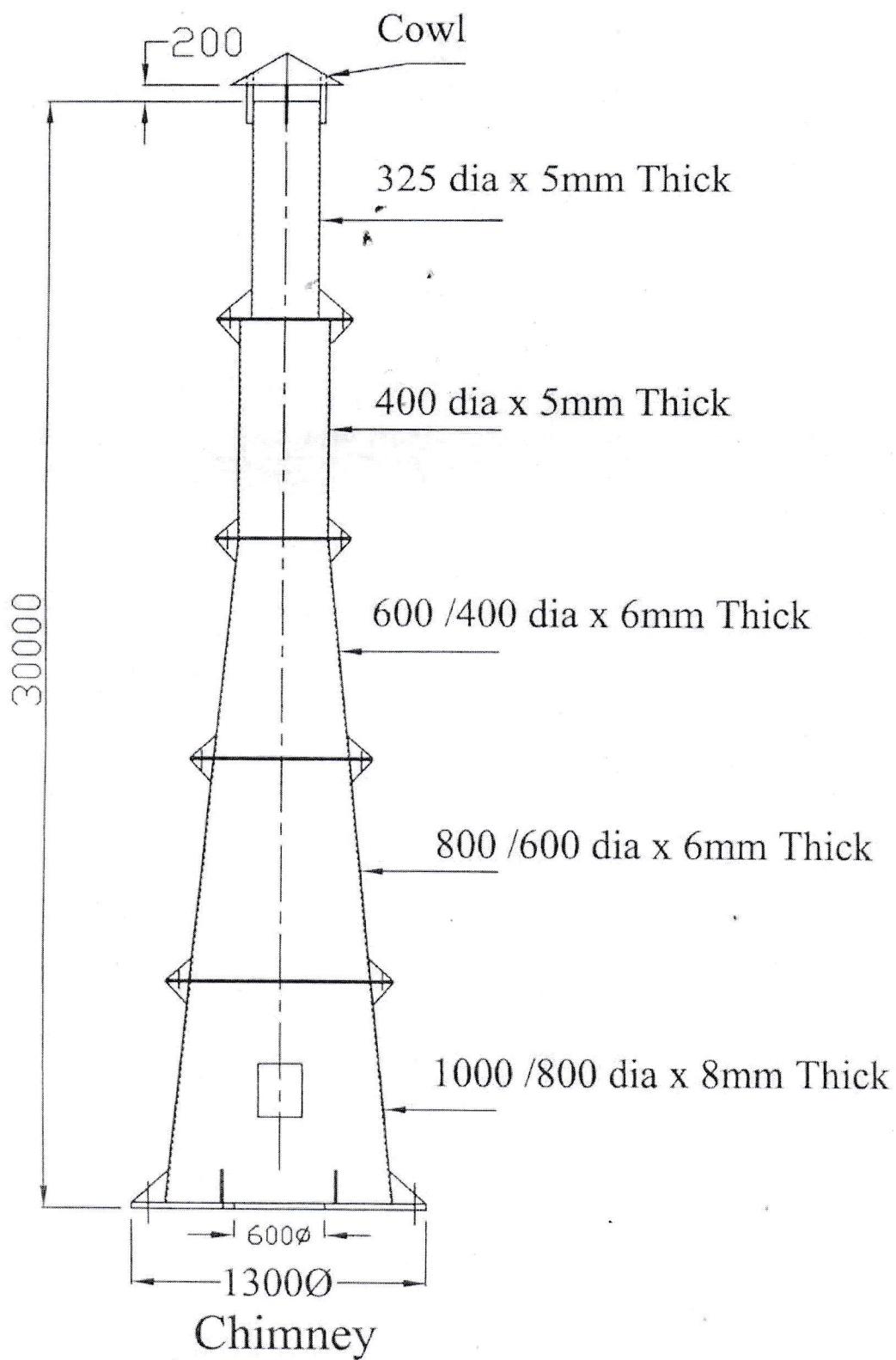

#- Depth of Concrete to be decided according to the soil condition

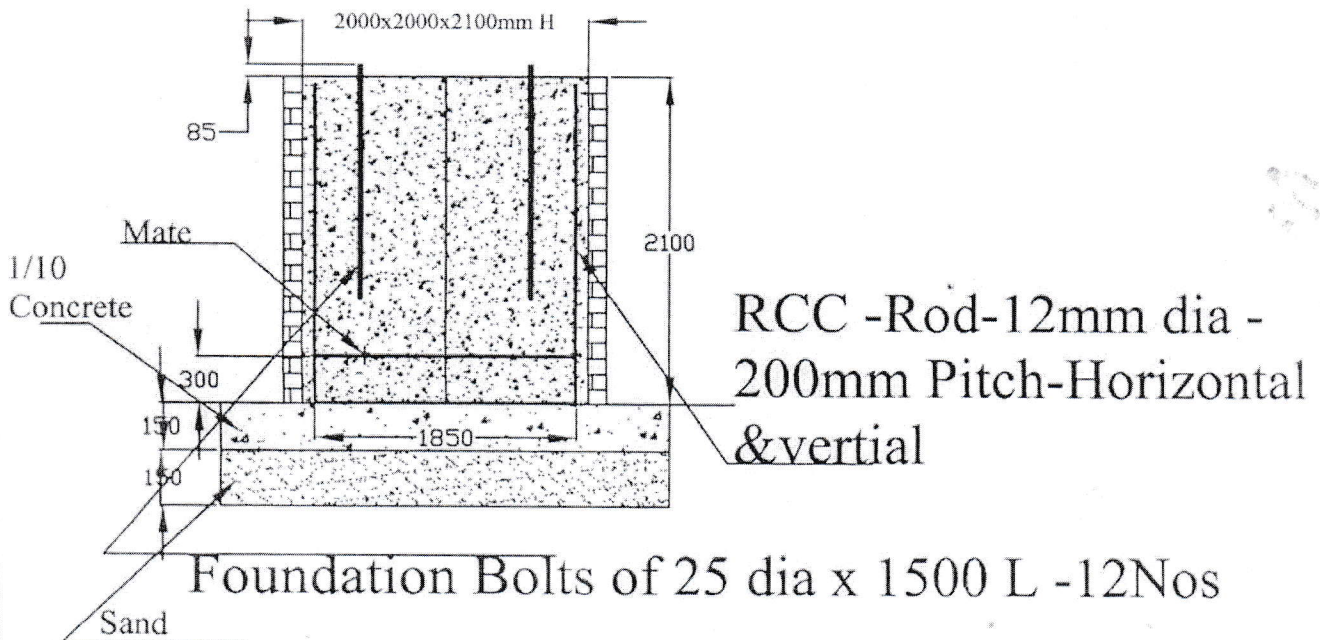
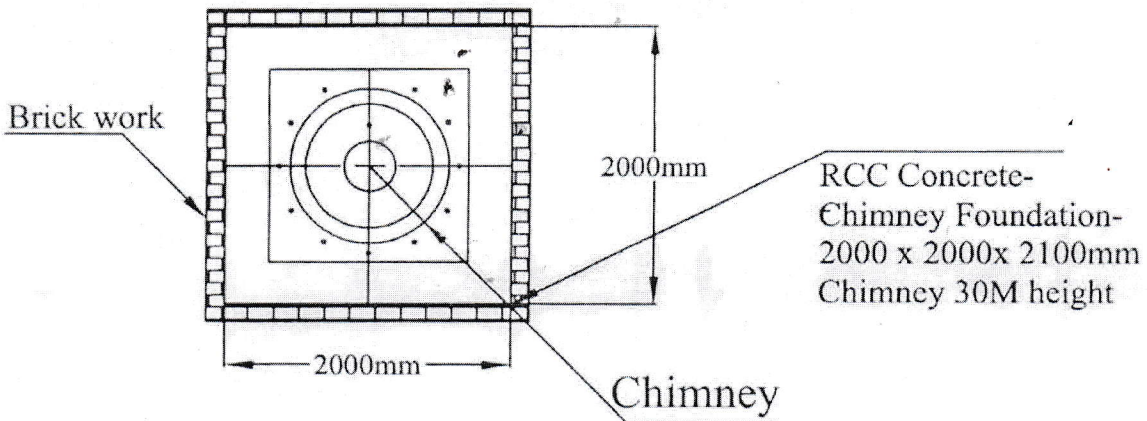

Chimney Foundation details -003

SPECIFICATIONS FOR CREMATOR (FURNACE AND CHIMNEY) FOR LPG

CREMATORIUM

The Furnace System comprises of:

1. Primary Combustion Chamber
2. Body Loading Trolley
3. Hot Duct
4. Secondary Combustion Chamber
5. Venturi Wet Scrubber
6. Mist Eliminator
7. Dilution System
8. Stack
9. Control Panel
10. Ash Chamber

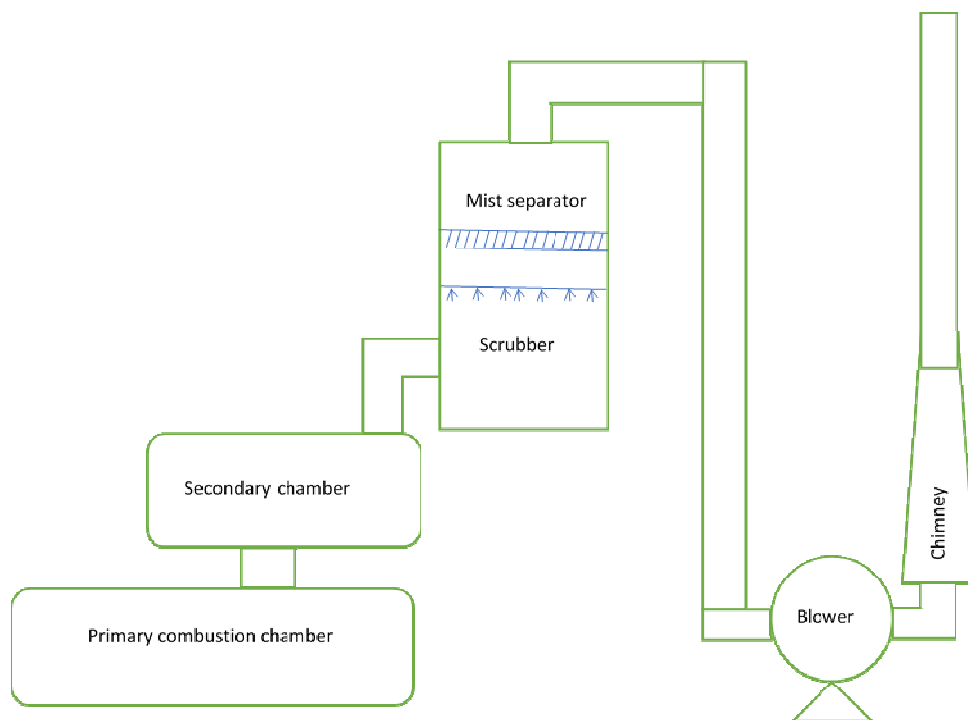

Process flow diagram

1. Technical Specifications

1. Primary Chamber : 9ft x 6ft x 5ft
2. Secondary Chamber : Sufficient Size so that a residence time of at least 1 sec at 1100⁰C is provided for the exit gases from the primary chamber to get exposed to the flame of the after burner.
3. Temperature in primary chamber : 800 ± 50⁰C
4. Temperature in Secondary Chamber : 1050 ± 50⁰C
5. Fuel : Liquified Petroleum Gas
6. Door of Primary Chamber : Front opening, vertical sliding, counter weight balanced with view port.
7. Burner System : Full length burners on either side of primary and secondary chamber
8. Gas pipe line : Made of Copper/M.S with pressure gauge
9. Insulation : Withstanding 1100⁰C
10. Chimney : 30m height
11. LP Gas cylinder : Minimum 8 number.
12. Power : Approximately 7kW, 3 phase connections
13. Emission : Parameters to meet KSPCB standards
14. Furnace bed & Structure : Stainless steel, strong, High quality alumina/fire bricks with air holes to secondary chamber.
15. Cremation time/body : 60-90 minutes.

16. LPG consumption : 12 ± 2 kg.

The following requirements are also to be satisfied

1. Wet Scrubber & cloud chamber : For the removal of toxic gases and particulate matter from the emission from the secondary chamber before letting out the emission into the atmosphere through chimney of 30m height.
2. Dilution system with ID Fan : To bring down further the concentration of pollutant parameters in the emissions.
3. Combustion Air Supply : With blower for the supply of oxygen for incineration of the body in the primary chamber and supply of excess air to the secondary chamber.
4. Trolley : Stretcher type trolley with rollers moving on ball bearings for easy sliding in of the body into the primary chamber.
5. Temperature Sensor : Cr/Al Thermocouple-one number in each chamber.
6. Temperature control and indication AC : Solid State digital type temperature indicator controller 0-1200°C in each chamber.
7. Safety controller : Solid state non-indicating controller 0+1200°C in each chamber to take care of control activity in case of failure.
8. Ash removal : At rear side of primary chamber, scraping by manual operation, with hinged type door manually operated.
9. Painting : Steel items to be enamel painted